

HYDRO PROKAV PUMPS (INDIA) PRIVATE LIMITED

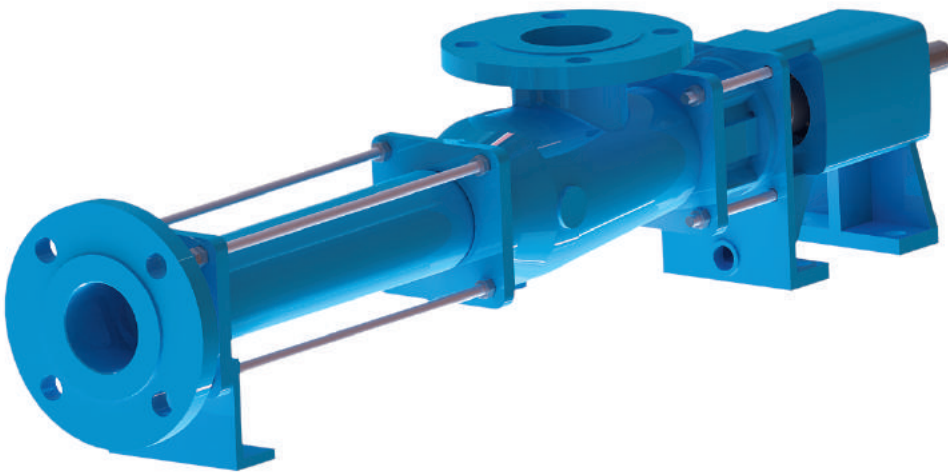

**Excellent
Pumping
Solutions with
Unmatched
Performance
The Real Economy
Best Versatility &
High Reliability**



**Where..
handling
is an art**

SALIENT FEATURES OF HYDRO PROKAV

- Lengthy Geometry
- Lengthy Pitch
- Lower Sliding Velocity
- Higher Capacity with lower rotor Dia & Eccentricity
- Increased service life
- Stability in pressure & flow due to longer sealing lines
- Reduced thrust loads on bearings & Universal joints
- Improved flow characteristics
- Reduced Vibration, Turbulence, Shear Rates & Pulsation
- Smooth and even performance
- Improved volumetric, Mechanical & Overall efficiency

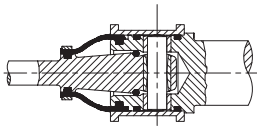
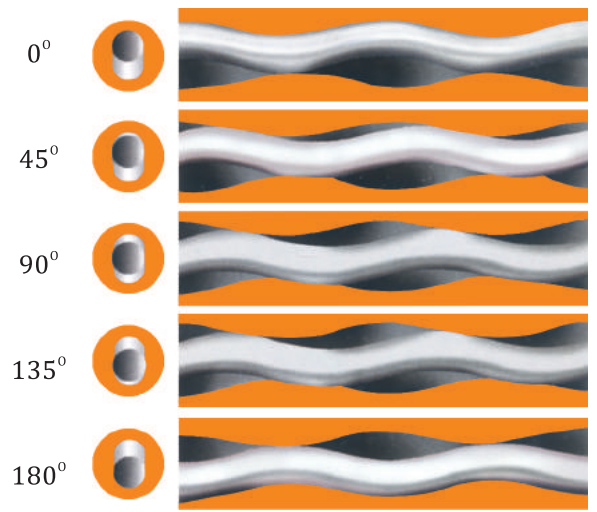

CROSS SECTION DRAWING OF
MULTIPLE PIN & BUSH
UNIVERSAL JOINT

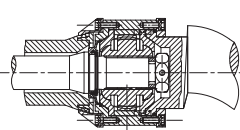

CROSS SECTIONAL
DRAWING OF GEAR JOINT

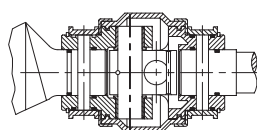

CROSS SECTIONAL DRAWING
OF CARDON JOINT

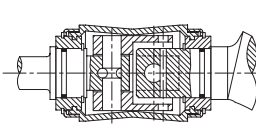

CROSS SECTIONAL DRAWING
OF CARDON JOINT

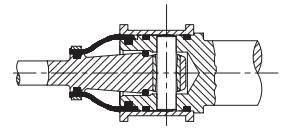

CROSS SECTION DRAWING OF
PIN & BUSH UNIVERSAL JOINT

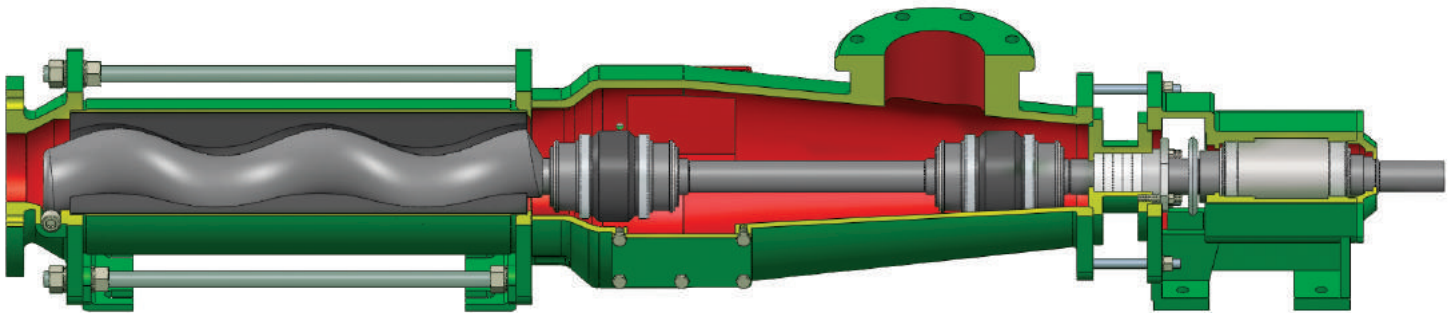

CROSS SECTIONAL DRAWING OF KYM SERIES PC PUMP

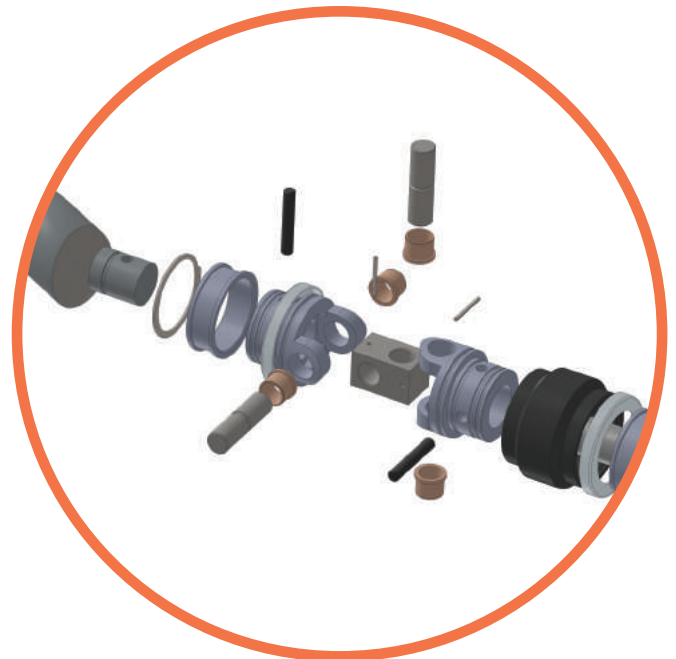
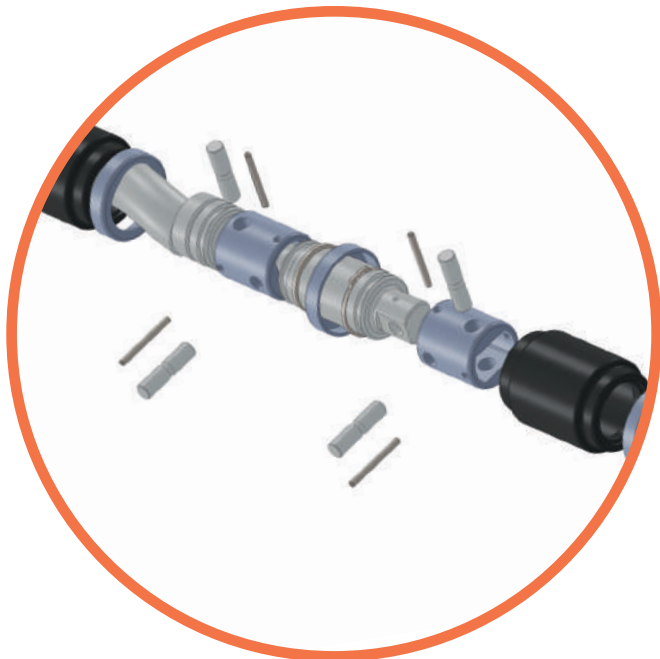

CARDON JOINT EXPLODED VIEWS

PROKAV'S PRODUCT RANGE TO SUIT ALL APPLICATIONS

KYM - A SERIES

SIZE	21	31	38	45	53	63	76	90	105	125	148	180
CAPACITY in Cu.M/Hr.	3.0	8.5	16	22	30	40	60	75	120	200	240	275
PRESSURE in BAR	30	36	48	48	48	48	24	24	24	18	18	18
SPEED (RPM)	1400	1400	1400	1400	1000	1000	750	750	750	600	400	400

KYM-A SERIES INDUSTRIAL AND CHEMICAL SCREW PUMPS



Capacity: 500 M³/HR, **Pressure-**48 Bar, **Temperature-**200°C, **Viscosity** -1,00,000 CST

Field of application: Ceramic Slurry and other Abrasive and Corrosive slurries, Masecuite, Effluents, Mineral Oils, Maize Starch Slurry, Viscose, Paints, Vegetable Oil, Sludge, Molasses, Magma, Dry seed & Sugar etc.,

Features: KYM - CD Pumps are of Cast iron construction with various metallurgy of rotating parts like Alloy Steel, Tool steel, SS 304 and SS 316 while KYM - CF pumps are of SS304 and SS 316 material of construction. Other various options of FRP / Ebonite lined housing with rotating parts in Super Alloys like Alloy 20, Hastelloy C, Hastelloy B, Titanium are available for highly corrosive applications. Shaft sealing ensured by soft gland packing/ mechanical seal. Torsion free metal bonded stator and double sealed universal joints as Pin & Bush Joints or Special Designs like Gear Joints or Cardon Joints as per customer requirements for longer service life and improved efficiency results in trouble free performance of the pumps.

KYM - B SERIES

SIZE	21	31	38	45	53	63	76	90	105	125	148	180
CAPACITY in Cu.M/Hr.	5	13	30	42	60	70	120	160	240	300	480	550
PRESSURE in BAR	6	6	6	6	6	6	6	6	6	6	6	6
SPEED (RPM)	1400	1400	1200	1200	1000	1000	750	750	750	600	400	400

KYM - B SERIES INDUSTRIAL AND CHEMICAL SCREW PUMPS



Capacity: 550 M³/HR, **Pressure-** 36 Bar, **Temperature-**200°C, **Viscosity-**1,00,000 CST

Field of application: Ceramic Slurry and other Abrasive and Corrosive slurries, Coating Slurry, Starch, GCC, OBA, AKD, Syrup, Sugar, Melt, Masecuite, Effluents, Mineral Oils, Maize Starch Slurry, Viscose, Paints, Vegetable Oil & Sludge etc.,

Features: KYM-B-CD Pumps are of Cast iron construction with various metallurgy of rotating parts like Alloy Steel, Tool steel, SS 304 and SS 316 while KYM-B-CF pumps are of SS304 and SS 316 material of construction. Other various options of FRP / Ebonite lined housing with rotating parts in Super Alloys like Alloy 20, Hastelloy C, Hastelloy B, Titanium are available for highly corrosive applications. Shaft sealing ensured by soft gland packing/ mechanical seal. Torsion free metal bonded stator and double sealed universal joints as Pin & Bush Joints or Special Designs like Gear Joints or Cardon Joints as per customer requirements for longer service life and improved efficiency results in trouble free performance of the pumps.

KYM - PK SERIES

SIZE	1.0	0.4	2.6	6	13	25	40	45	60	62	90	100	120
CAPACITY in Cu.M/Hr.	0.2	0.35	1.8	4.0	9.0	20	35	40	50	60	80	90	100
PRESSURE in BAR	24	24	24	24		24	24	24	24	24	24	24	24
SPEED (RPM)	1400	1400	1400	1400		1000	1000	750	750	750	600	400	400

KYM - PK SERIES INDUSTRIAL AND CHEMICAL SCREW PUMPS



Capacity : 100 M³/HR, **Pressure-**24 Bar, **Temperature-**200°C, **Viscosity** -1,00,000 CST

Field of application : All types of Abrasive, Corrosive, high consistency, fibrous, viscous and non viscous slurries/ Sludge with solid suspensions which are generally considered un-pumpable.

Features : PK Series 6f Pumps are designed with special Geometries in 1/2 as well as 2/3 profiles. While Cast Iron and SS 316 material of construction are offered, Special materials of construction are available for highly corrosive fluids. Shaft sealing ensured by soft Gland Packing / mechanical seal. Torsion free metal bonded stator and double sealed universal joints for longer service life and higher efficiency.

KX - W SERIES

SIZE	21	31	38	45	53	63	76	90	105	125	148	180
CAPACITY in Cu.M/Hr.	3.0	8.5	16	22	30	40	60	75	120	200	240	275
PRESSURE in BAR	30	36	48	48	48	48	24	24	24	18	18	18
SPEED (RPM)	1400	1400	1400	1400	1000	1000	750	750	750	600	400	400

KX - W SERIES WIDE THROAT CHEMICAL AND HYGIENE SCREW PUMPS



Capacity : 275M³/HR, **Pressure -** 36 Bar, **Temperature-**200°C, **Viscosity-**1,00,000,00 CST

Field of application : Cake Mix, Grease, Water Asbestos Slurry, Explosive slurry, High Consistency Paper Pulp, Grout mix, Printers ink Paste, Pulp Concentrates, Jam, Chawanaprash, Yoghurt, Creams and other media termed as Non Newtonian Fluids, Magma, Masecuite.

Features : Hopper type suction inlet allowing gravity flow of Plastic - Viscous media on to Augur cum Coupling Rod pushing viscous substances into pumping cavity. Standard Pumps employ Mild Steel Hopper Pump Casing with alloy steel rotating parts. For corrosive or hygienic duty, all contact parts will be in SS material. Shaft sealing by soft Gland Packing / Mechanical Seal. Delivery connection in BS, ISO, ASA, ANSI flanged ends and for hygiene applications, IDF / SMS / Triclover or equivalent are used. Bridge Breaker Paddle assembly is available as option for products forming bridge while handling high consistency media and referred as KWBB Series of Pumps.

KX - F SERIES

SIZE	21	31	38	45	53	63	76	90	105
CAPACITY in Cu.M/Hr.	3.0	8.5	16	22	30	40	60	75	120
PRESSURE in BAR	30	36	48	48	48	48	24	24	24
SPEED (RPM)	1400	1400	1400	1400	1000	1000	750	750	750

KX - F SERIES QUICK CLEAN HYGIENE SCREW PUMPS



Capacity : 75M³/HR, **Pressure-** 12 Bar, **Temperature-**120° C, **Viscosity** - 10,00,000 CST

Field of application : Acids and Alkaline slurry, Alum, Bentonite slurry, Casein Slurry, Ceramic Slurry, Coating Mix, Detergent slurry, Dewatered Sludge, Electroplating solution, Emulsions, Ferrite slurry, Flocculent, Glue, Grout Mix, Gum Sludge, Industrial wastes, Latex, Lube Oil, Magma, Masecuite, Molasses, Oil sludge, Paint, Paperpulp, Petroleum jelly, Polyelectrolytes, Printing ink, Resins, Soap stock, Sodium Silicate, Spent wash, Varnish, Vegetable oil, Viscose, Water to Thickened Sludge, Yeast etc.,

Features : Compact Configuration of Screw Pump in which the Pumping Parts are coupled directly to the drive thereby eliminating the Bearing Housing. Suitable for restricted spaces of operation or Mobile Pump Sets apart from low maintenance and cost effectiveness ensuring long service life. Various Material of Construction are offered to suit varied applications in CI, CS, Ss304, Ss316 etc., while Stators will be of Natural, Nitrile, EPDM, Neoprene, Hypalon, Viton, Silicon, Butyl, Hi-Nitrile, Buna Poly Butadiene, etc.,

KYMCC SERIES CLOSE COUPLED COMPACT PUMPS



Capacity : 200M³/HR, **Pressure -** 48 Bar, **Temperature-**200°C, **Viscosity-**10,00,000 CST

Field of application: Fruit Pulp, Fruit Juice, Honey, Condensed milk, Butter Oil, Glucose, Cream, Curd, Yeast, Icecream, Pharmaceutical Formulations, Syrup, Malt Extract etc.,

Features : Hygienic design pump with all metal parts in contact with liquid in smooth SS and stator of non-contamination rubber, Seamless body eliminating product retaining pockets. Shaft sealing by food grade soft Gland Packing / mechanical seal. IDF/SMS/TRICLOVER/ equivalent end connections.

Capacity : 10M³/HR, **Pressure-**12 Bar, **Temperature-**120°C, **Viscosity-**10,00,000 CST

Field of application : Acids, Beer, Diesel Oil, Lubricating Oil, Furnace Oil, Drug formulations, Varnish, Chemical Solutions, Grease, Cream, Putty, Ink paste, Glucose, Malt Extract, etc.,

Features : Portable design vertical screw pumps for emptying barrels. Driven by vertical flange mounted Geared or Flanged Motors. Available in MS or SS construction with rotating parts to suit duty conditions. Shaft sealing by soft Gland Packing / Mechanical seal.

KB SERIES VERTICAL / DRUM / BARREL SCREW PUMPS



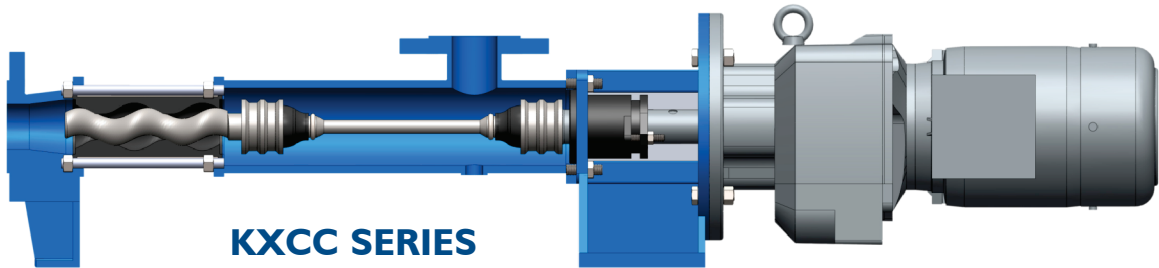

KXCC SERIES

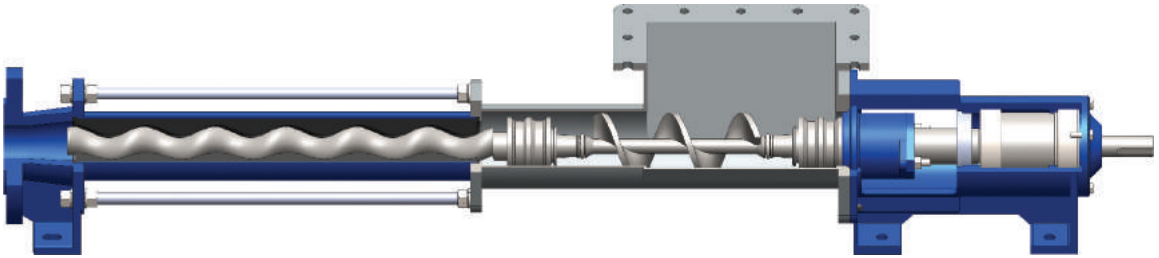

KXW SERIES

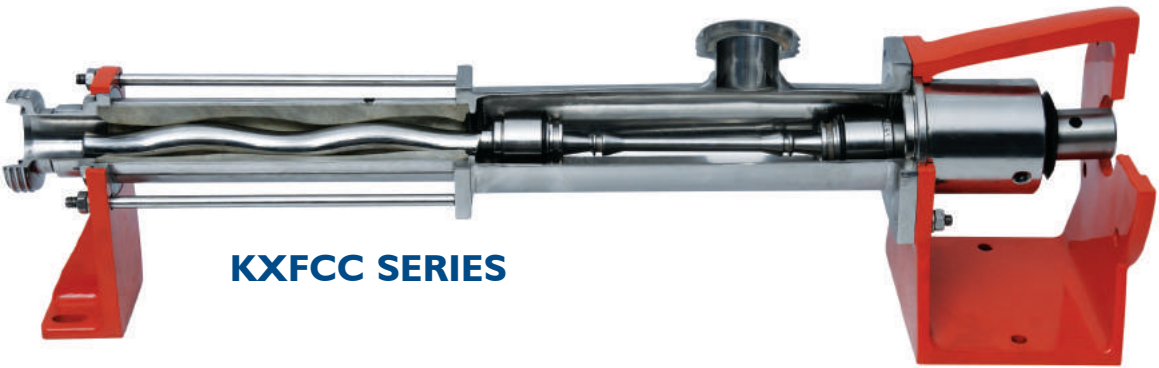

KXFCC SERIES

THE PROKAV'S EXPERTISE

Hydro Prokav's New Integrated Manufacturing Plant Located at the Industrial City of Coimbatore, India is spread over 25,000 Sq. Mts. The Plant comprises of Full Fledged Rubber Unit with Test Labs. The Modern Plant also comprising Highly Sophisticated CNC Machining Unit for manufacturing Critical components of Progressive Cavity Pumps with High Precision and Excellence. The Computerised Test Bed Facility Doubly ensures High Standards of Testing and Performance Evaluation. Backed up with a very Sophisticated R&D center, Hydro Prokav aims at bringing more Versatile Designs to suit the entire demands of the Processing Industries.

Hydro Prokav Progressive Cavity Pumps are preferred by Customers spread across 40 countries World Wide with more than 5000 customers catering to more than 10,000 fluids offering the finest solution for their various Pumping Requirements.

Hydro Prokav Genuine Progressive Cavity Pumps are available through a wide network of Branches in all Major Cities in India, with Marketing Office situated at USA, China, and Distributors and Dealers spread in Europe, Africa, Middle East, Australia and South East Asian countries.



**HYDRO PROKAV PUMPS
(INDIA) PVT. LTD.,**

H.O & Works : S.F. No. 1/18-1, Palladam Main Road,
Othakkalmandapam, Coimbatore - 641 032. Tamil Nadu. INDIA
Contact : +91 - 93442 48441, +91 - 99449 35332, +91 - 99449 35334
E-mail : sgiri@hppumps.com, priya@hppumps.com, ceo@hppumps.com
URL : www.hppumps.com

